



Part-financed by the European Union  
(European Regional Development Fund  
and European Neighbourhood and  
Partnership Instrument)



# Integrated Urban Development Concept of Jugla Rīga, Latvia

Presented by Normunds Strautmanis

Rīga, 2 December 2011

Urb.Energy Final Conference

# Integrated Urban Development Concept of Jugla (1/2)

- IUDC for Jugla is an urban planning document, first of its kind in Latvia, with focus on a particular neighbourhood of a city
- The aim of the integrated concept is to reach a high and long lasting residential and economical quality of the particular neighbourhood of Riga – Jugla,
- while paying a lot of attention to energy efficient solutions thus ensuring sustainability of the planned development.



# Integrated Urban Development Planning

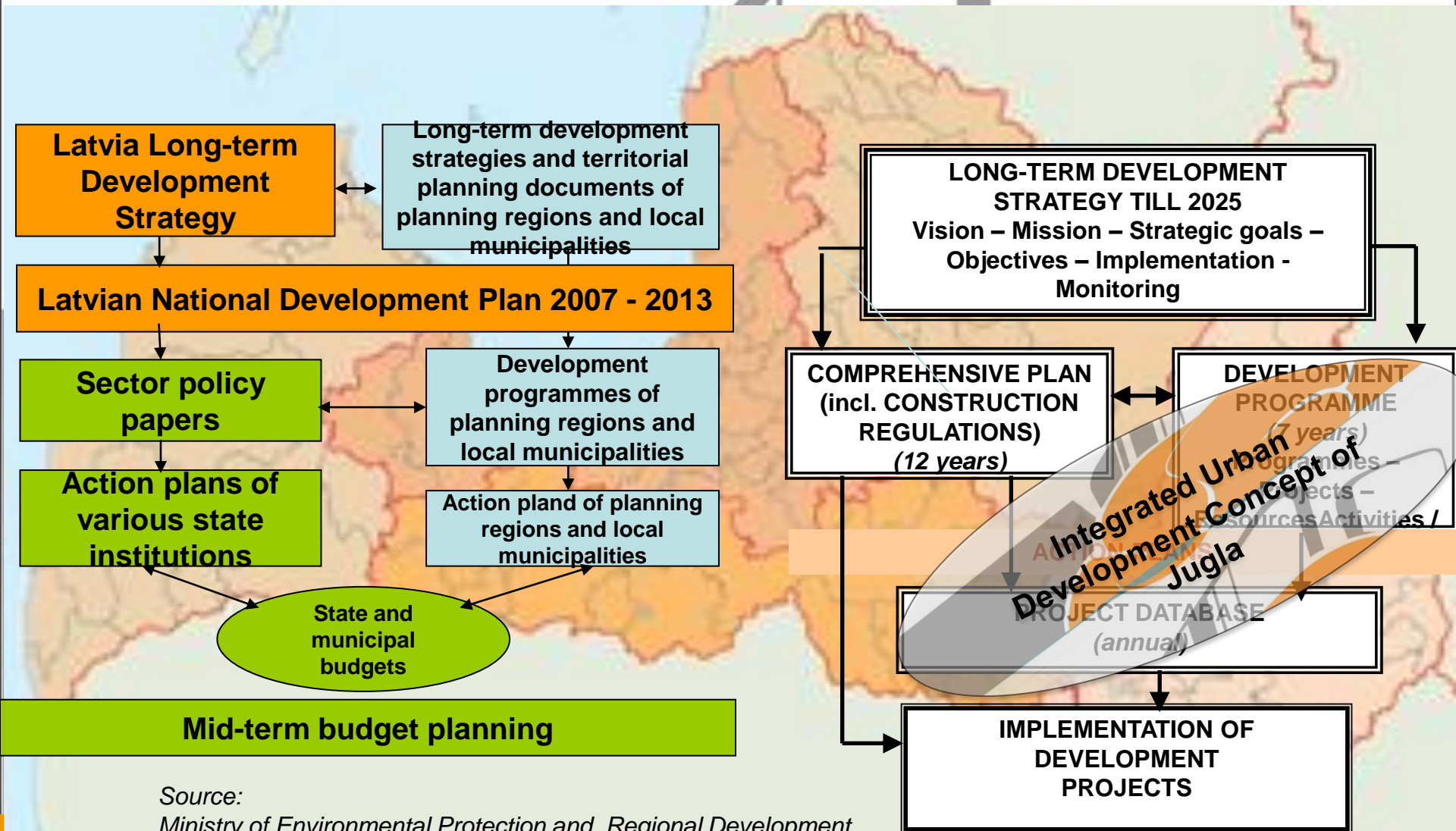

Source:  
Ministry of Environmental Protection and Regional Development  
and City Development Department of Riga City Council

# Integrated Urban Development Concept of Jugla (2/2)

- [1] Sustainable development concept for Jugla
- [2] Energy supply concept of Jugla
- [3] Concept for energy efficient renovation of the building stock of Jugla
- [4] Financial concept for urban improvements in Jugla
- [5] Financial concept for improved energy supply system of Jugla
- [6] Financial concept for energy efficient renovation of the building stock of Jugla
- The IUDC of Jugla includes results of additional surveys and analyses, all elaborated within the *Urb. Energy project*.

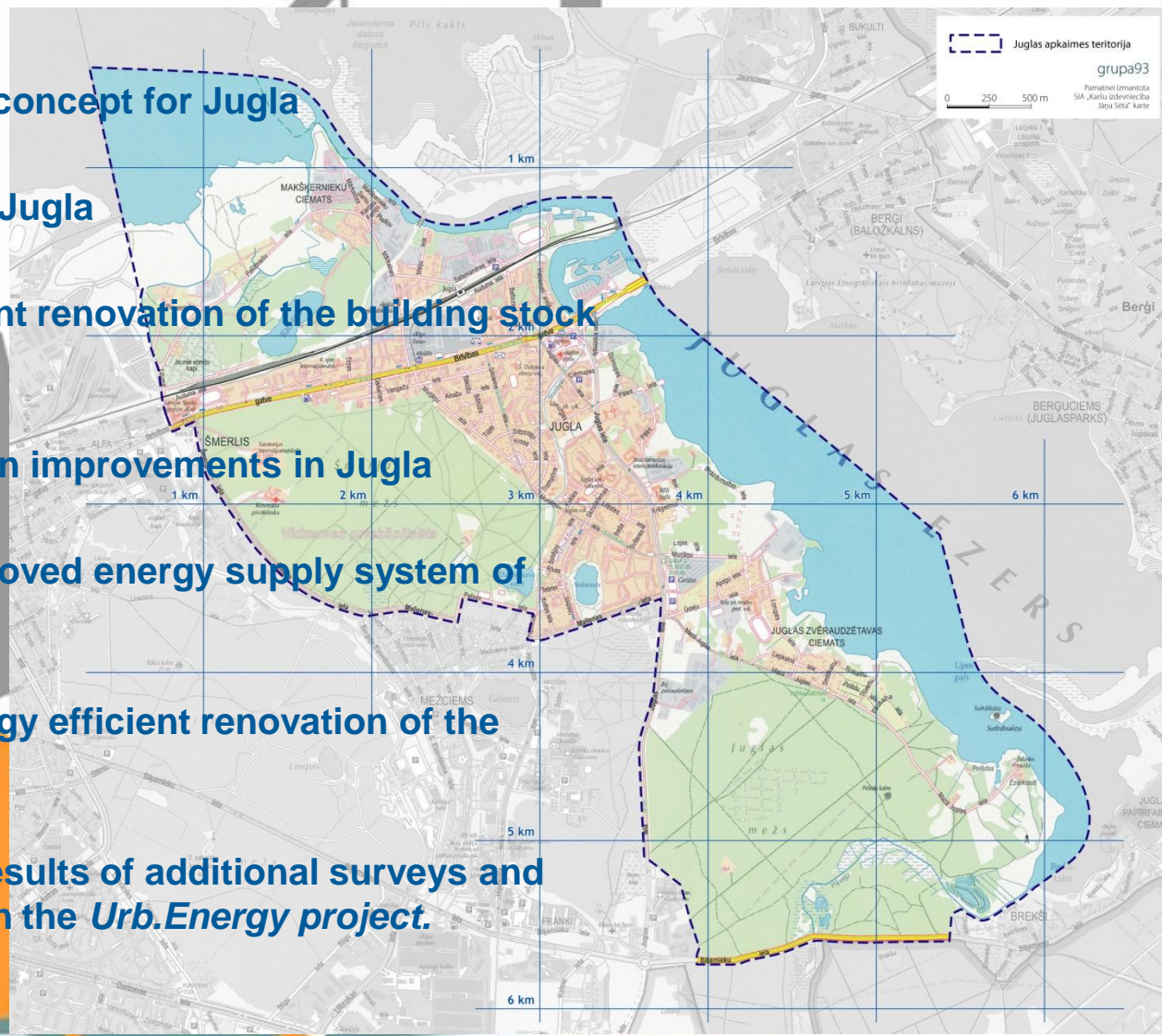

# Sustainable development as a core principle

## Jugla - residential neighborhood of high quality

- Energy efficiency as part of IUDC including
  - Energy supply concept
  - Financial strategy on how to apply EE measures
  
- 3 fields
  - Urban areas (urban development)
  - Housing stock (multi-apartment buildings)
  - Energy supply



# Jugla IUDC: from needs to actions

- **Methodology: 4 stages**
  - (1) priority goals to achieve according to Riga Development Programme 2006 – 2012 set
  - (2) detailed SWOT analysis of Jugla neighbourhood carried out stating the issues to be covered within IUDC
  - (3) sustainable development concept for Jugla neighbourhood elaborated where the activities to solve the issues were found
  - (4) financial concept on how to finance the activities elaborated



# I - Rīga Development Planning

- Rīga Long-term Development Strategy till the Year 2025

- Sets mission of the city  
**/RĪGA – Opportunity for Everyone/**

- States development priorities

- Sets priority and strategic goals and priority aims to achieve

PA4 “Life in a city with qualitative neighbourhoods”

SG10 “Green city with good environmental quality”

SG12 “A city with qualitative dwellings”.



- Rīga Development Program 2006 - 2012

# II – SWOT analysis of Jugla: Strengths



**Pilsētvide**  
**Urban**  
**development**

**Daudzdzīvokļu**  
**ēkas**  
**Multi-apartment**  
**buildings**

**Energoapgāde**  
**Energy supply**

- Spatial composition of Jugla neighbourhood consisting both of living, commerce, and nature
- Location of the neighbourhood and
- Transport network passing Jugla are very good prerequisites for future development of Jugla
- The existing multi-apartment building stock provides accommodation to 95% of inhabitants of Jugla
- Operation of the building stock can be continued.
- Good current technical condition of combined heat and power (CHP) plants and district heating grid
- Almost 90% of heat energy is produced in CHP cycle and 100% of electricity is produced in CHP cycle
- Heat losses in grid have been reduced by more than a half and are now stabilized at 13% which is an appropriate level for an up to date city district heating system security



# II – SWOT analysis of Jugla: Weaknesses



## Pilsētvide Urban development

- Outdated public outdoor infrastructure elements,
- Shortage of overnight parking, and
- Disrepair quality of high rise apartment blocks inner yards could lead to further degradation of Jugla neighbourhood resulting in loss of inhabitants and work places

## Daudzdzīvokļu ēkas Multi-apartment buildings

- Quality of the buildings is often poor
- Apartment owner awareness of this and activity to solve the problems is low

## Energoapgāde Energy supply

- Due to the growing electricity demand in Riga and Jugla it might not be possible to significantly increase the share of electricity produced by renewable energy sources (RES).

## II – SWOT analysis of Jugla: Opportunities

### Pilsētvide Urban development

- Existing infrastructure,
- Availability of greenfields and
- Good transport coverage, developed further, can operate as basis for attraction of new inhabitants and work places to neighbourhood



### Daudzdzīvokļu ēkas Multi-apartment buildings

- It is possible to solve the problems of the buildings by renovation
- It is also possible to develop an appropriate organizational and financial scheme that would overcome inhabitant lack of awareness

### Energoapgāde Energy supply

- The existing natural gas storage infrastructure in Latvia is uniquely appropriate for energy resources storage in a gas state
- The existing natural gas transmission grid will be available after Year 2014 for all gas producers and suppliers, including those who produce and supply sufficiently qualitative gas fuel produced using RES

# II – SWOT analysis of Jugla: Threats



**Pilsētvide**  
**Urban**  
**development**

- Lack of actions by city municipality, not starting the elimination of existing problems in neighbourhood properly and on time, can endanger the future development of the neighbourhood significantly

**Daudzdzīvokļu**  
**ēkas**  
**Multi-apartment**  
**buildings**

- The realization of a large-scale building renovation is not possible without political solution but the political awareness of building stock problems and the urgent need of renovation is still very low and hard to overcome;
- The technical condition of not renovated prefabricated panel buildings can deteriorate fast

**Energoapgāde**  
**Energy supply**

- The current share of natural gas use makes energy production dependant on gas supplier
- The increase of natural gas costs in Latvia has reached 400% in the recent decade

## III – Problems / Needs (1/3)



Pilsētvide  
Urban  
development

- P1.1 Public outdoor space is of low quality
  - a) Inner yards of high rise apartment blocks are of poor quality
  - b) Greenfields, waterfronts and woods are undeveloped
  - c) Overnight parking issue within neighbourhoods is very actual
  - d) Public outdoor space is not suitable for handicapped and old people
- P1.2 Exterior of housing blocks is of poor visual quality
- P1.3 Part of territories suitable for future development has difficult or specific conditions
  - a) Part of the territory has adverse and difficult building conditions due to

## III – Problems / Needs (2/3)



Daudzdzīvokļu  
ēkas  
Multi-apartment  
buildings

- P2.1 Technical quality of multi-apartment buildings is low
- P2.2 Quality of indoor climate of apartments is very low
  - a) Air humidity in apartments is often too low or too high
  - b) CO2 level in apartments is often extremely high
  - c) Inside air temperature in apartments often is too low or too high
- P2.3 Heat energy consumption of multi-apartment buildings is very high  
realize the necessity of renovation, do not believe that quality can be ensured and do not trust private building managers

# III – Problems / Needs (3/3)

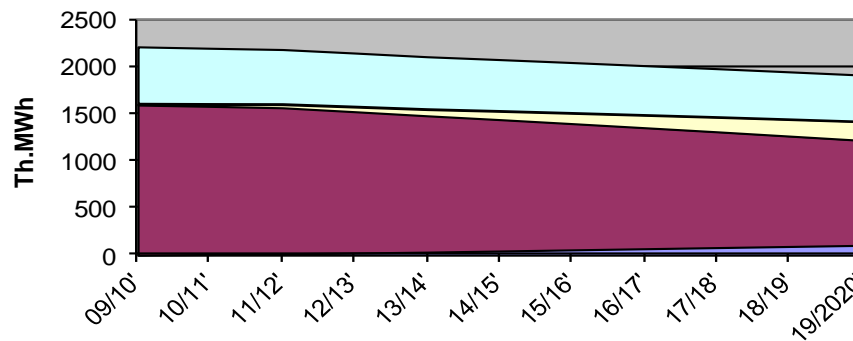

Forecast of heat consumption by district heating system in Riga from CHP plants TEC1 and TEC2: a scenario where heat consumption reduction by building renovation is **not compensated** by new heat loads. (Light blue area – the existing public buildings; Yellow area – new public buildings; Brown area – the existing multi-apartment buildings; Dark blue area – new multi-apartment buildings.)

- **P3.1 The share of renewable energy in Riga is low**
  - a) Biogas currently is used only locally
  - b) Integration of biogas and natural gas distribution networks is not possible currently
  - c) Use of fossil fuel creates CO2 emissions
- **P3.2 Use of fuel for energy production in local heat sources creates air pollution**
  - a) Use of fuel for energy production in local heat sources creates NO<sub>x</sub> pollution in air
  - b) Use of fuel for energy production in local heat sources creates mechanical particle pollution in air

# III - Development actions (1/3)

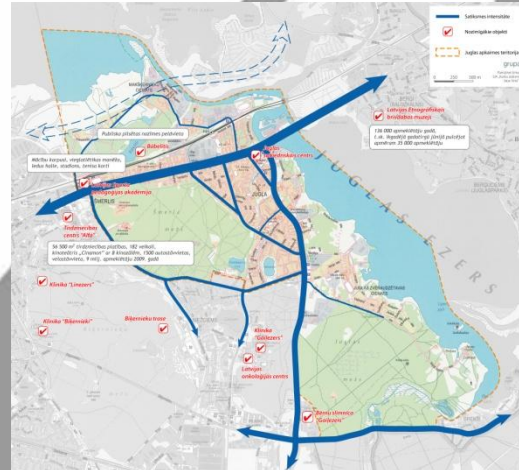

**Pilsētvidē  
Urban  
development**

- **A1.1 Provision of overnight parking facilities for high rise apartment blocks' inhabitants**
- **A1.2 Reconstruction of existing greenery and creation of new ones, improvement of Strazdupīte River area**
- **A1.3 Improvement of high rise apartment blocks' inner yards (reconstruction of greenery, reconstruction of benches and lightning infrastructure, provision of small architecture forms and other public outdoor elements)**
- **A1.4 Adaption of infrastructure for old and handicaped people**

# III – Development actions (2/3)

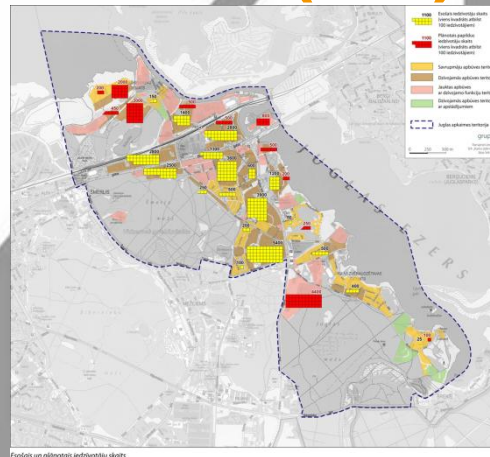

**Daudzdzīvokļu ēkas**  
**Multi-apartment buildings**

- **A2.1 Renovation of multi-apartment buildings in Jugla**
- **A2.2 Preparation of a one, unified product *building's renovation that can be easily understood by the apartment owners***
- **A2.3 Supplementation of the normative acts with a statement that renovation of ventilation system is a mandatory part of building renovation**
- **A2.4 Integration of fire-prevention standards and energy efficient building renovation**



# III – Development actions (3/3)

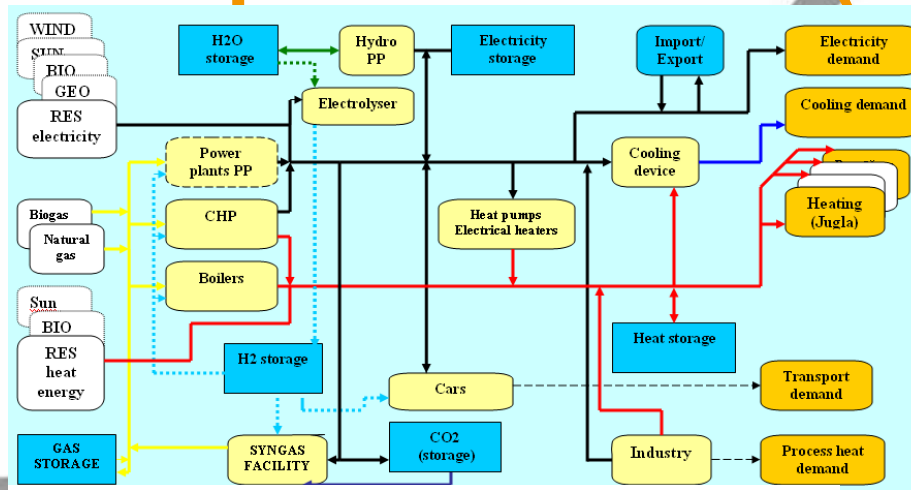

Pic. Scheme of possible development of energy supply system of Riga

Energoapgāde  
Energy supply

- A3.1 Restriction of construction of local heat sources in city areas where  $\text{NO}_x$  and mechanical particle concentration in air is high
- A3.2 Connection of local heat source consumers to the district heating system
- A3.3 Raise of energy production efficiency
- A3.4 Increase of biogas production and use after the gas supply market liberalization

# III – Development actions: Projects (1/5)

**Pilsētvide**  
**Urban**  
**development**

- **Construction of recreation path in Šmerlis wood**
  - 8 km in length
  - For cycling and pedestrians
  - For Skiing in winter
  - Including vista tower
  - Costs estimated at Ls 51 thousand (72.5 thousand EUR)

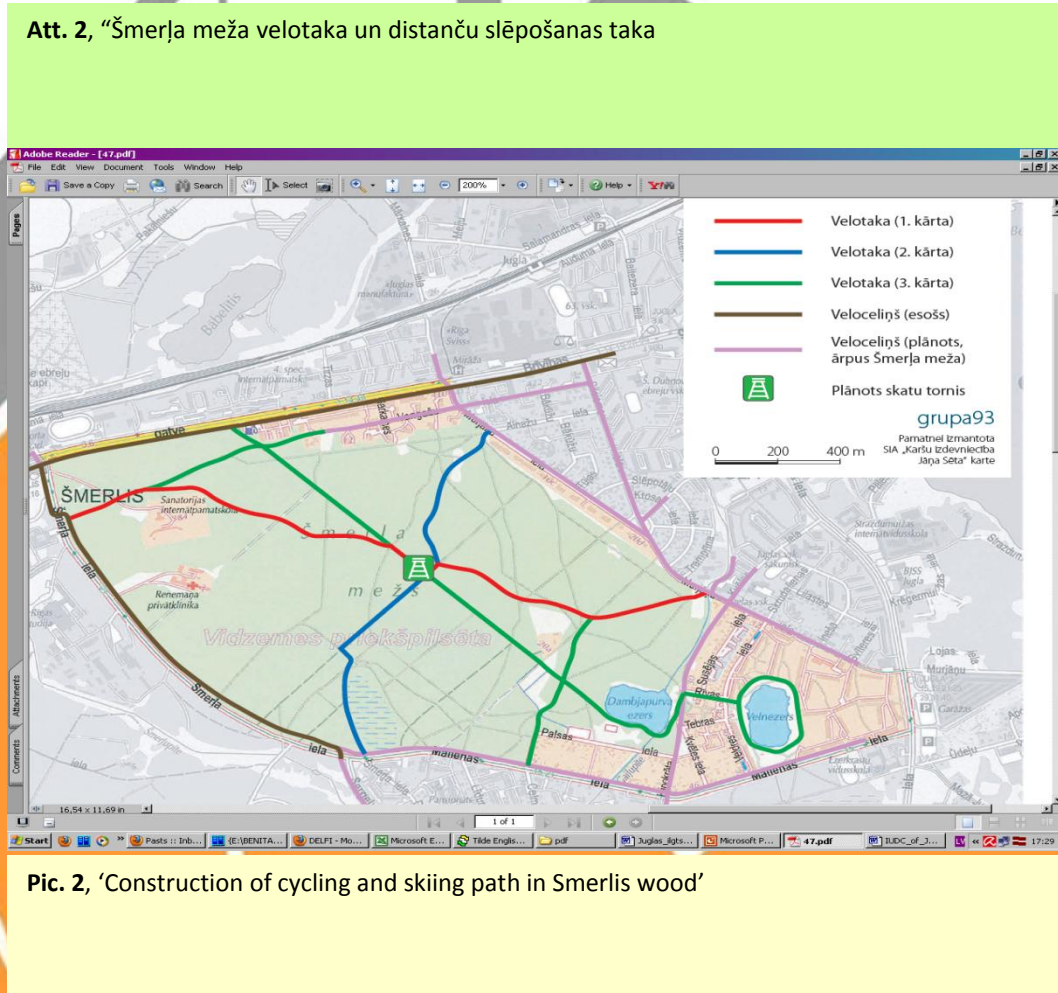

## III – Development actions: Projects (2/5)

**Pilsētvide**  
**Urban**  
**development**

- **Facilitation of Strazdupīte river**
  - To improve accessibility of the territory
  - New pedestrian bridges
  - For use of bicycles as well
  - New open public space (outdoor gym)
  - Costs estimated at Ls 59 thousand (84 thousand EUR)

Att. 3 'Strazdupītes apkārtnes labiekārtošana'

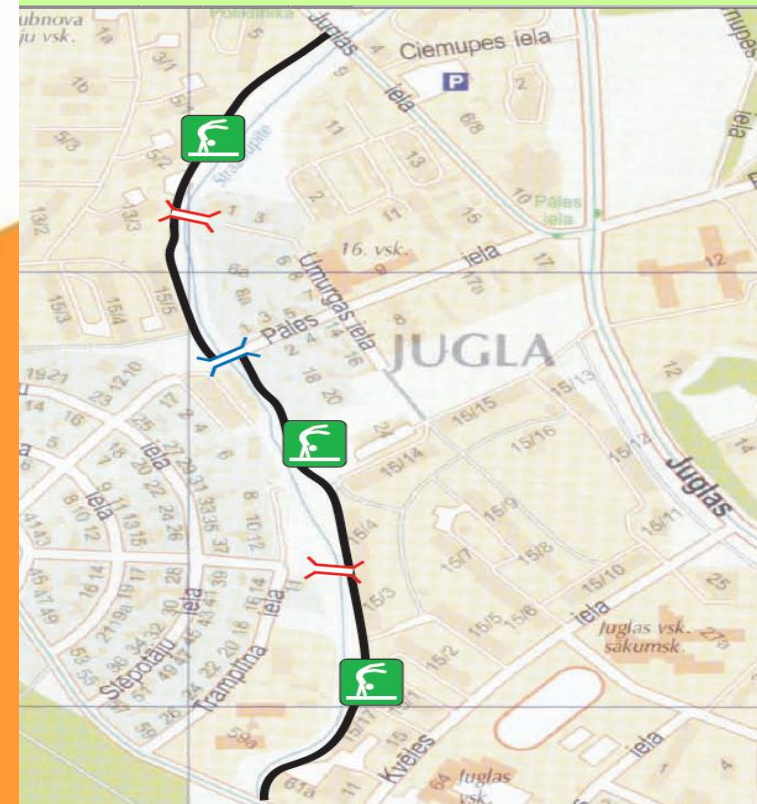

Pic. 3 'Facilitation of Strazdupite river'

# III – Development actions: Projects (3/5)

**Pilsētvide**  
**Urban**  
**development**

- **Facilitation of the lakeshore of Jugla lake**
  - Pedestrian and bicycle paths
  - New public outdoor space
  - Facilitation of swimming place
  - Boat dock
  - Outdoor sports facilities
  - Costs estimated at Ls 475 thousand (676 thousand EUR)



# III – Development actions: Projects (4/5)

- **Development of parking lots**
  - 5 possible solutions
  - For 25 up to 300 cars
  - Costs estimated from Ls 4 500 up to Ls 1.6 million (7500 EUR – 2.27 million EUR)

**Pilsētvide  
Urban  
development**



# III – Development actions: Projects (5/5)

- Development of Auduma street and pedestrian crossing over railway
  - To improve accessibility and interconnectivity of Jugla parts
  - New railway crossing for cars, pedestrians and bicycles
  - Costs estimated at Ls 4.2 million (6 million EUR)

Pilsētvide  
Urban  
development



# IV – Financing and organization (1/3)

- F1.1 Allocation of resources from municipal budget for neighbourhoods' development
- F1.2 Establishment of Municipal neighbourhoods' development fund
- O1.1 Appointment of structural unit within municipality responsible for integrated development of neighbourhoods
- O1.2 Elaboration, approval and implementation by city council of neighbourhood development plan with integrated urban development approach for Jugla (and other 57 neighbourhoods of City of Riga)

Pilsētvide  
Urban  
development



# IV – Financing and organization (2/3)

Daudzdzīvokļu  
ēkas  
Multi-apartment  
buildings

- **F2.1 Development of a revolving fund for financing of multi apartment building renovation**
- **F2.2 Provision of co financing also for those renovation measures that do not improve building's energy efficiency**
- **O2.1 Establishment of a Municipal Energy service company (a specialized Municipal building renovation company)**





## IV – Financing and organization (3/3)

Energoapgāde  
Energy supply

- F3.1 Use of the existing EU financial mechanisms for rise of energy production efficiency
- F3.2 Establishment of financial mechanisms to support projects for promotion of biogas use
- F3.3 Continuation of financial support mechanisms to increase the share of renewable energy sources in energy production



# Summary evaluation of IUDC approach in City of Riga, Latvia

- **Success factor**
  - Sets real solutions for real local problems of development
- **Innovation**
  - First such document for City of Riga
- **Challenge**
  - To approve by Riga City Council to become an official document (action plan)
- **Shortcoming**
  - Formally not elaborated as part of city development planning system / process





**Paldies par uzmanību!**  
**Thank you very much!**  
**Vielen Dank!**

**[www.urbenergy.eu](http://www.urbenergy.eu)**

**Normunds Strautmanis**  
**Urban Expert for *Urb.Energy* project**  
**[Normunds.Strautmanis@riga.lv](mailto:Normunds.Strautmanis@riga.lv)**